

BIOGAS AS VEHICLE FUEL

*Martin Fransson, BioMil AB
2014-02-12*

BioMil AB

biogas, environment & recycling

BioMil AB

COMPANY PRESENTATION

Consultant company with engineering and environmental specialists

Unique expert knowledge in biogas systems

Office in **Lund**, Halmstad and Göteborg

Founded 1979 - over 30 years of experience

Over 200 references within the field of biogas

BioMil AB

biogas, environment & recycling



BioMil AB

SERVICES

- Studies and assessments
- Business & Project development
- Plant & Process design (detailed design)
- Procurement and Commissioning
- Operating support
- R&D with in-house laboratory
- Education
- LCA, Life Cycle Assessment
- EIA, Environmental Impact Assessment

EXAMPELS OF CLIENTS

- *Energy and waste management companies*
- *Municipalities*
- *Private companies*



Region Skåne



**FEDERATION OF
SWEDISH FARMERS**



BioMil AB

Biogas as vehicle fuel

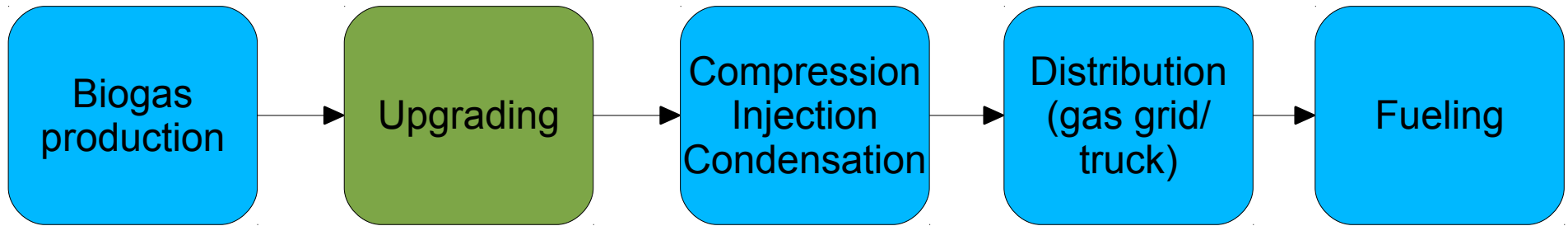

BioMil AB

NEW REPORT

- *Biogas upgrading – Review of commercial technologies*
- Published 2013 by Swedish Gas Technology Center



<http://www.sgc.se/ckfinder/userfiles/files/SGC270.pdf>

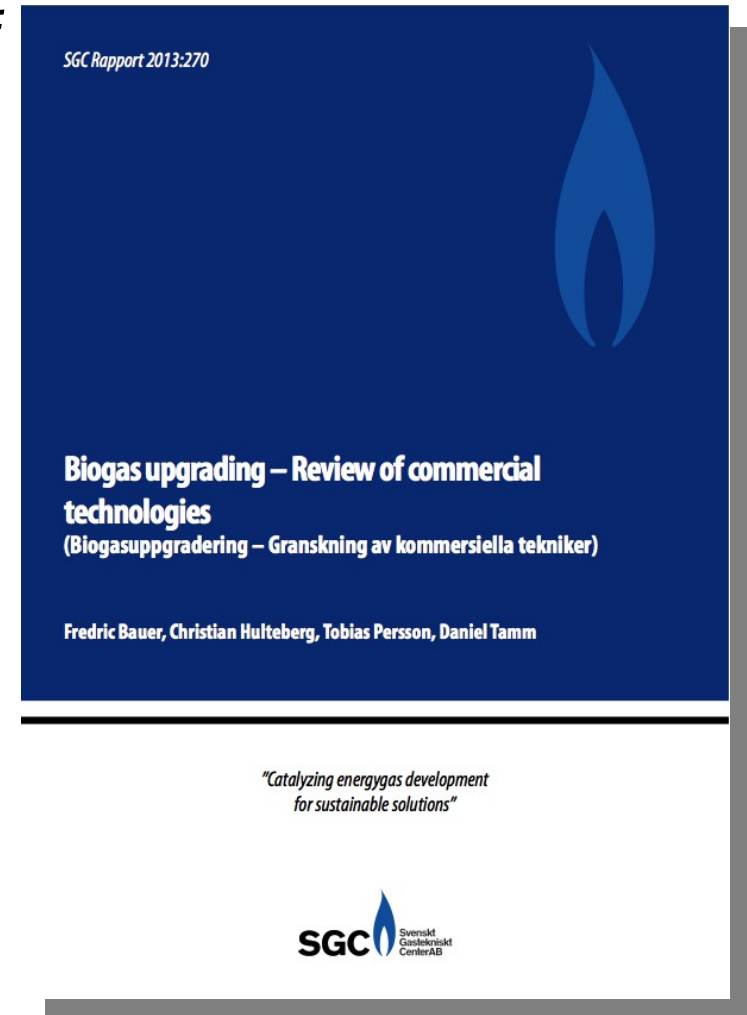

BioMil AB

Why biogas upgrading?

Biogas from anaerobic digestion:

~63 % methane

~33 % carbon dioxide

~1 % nitrogen

~3 % water

hydrogen sulphide

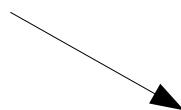

-Vehicle fuel according to Swedish Standard SS 15 54 38:

95 - 99 % methane

< 5 % carbon dioxide, nitrogen, oxygen

< 1 % oxygen

a low water content, dp -60°C

To achieve a heating value corresponding to the gas quality in the natural gas grid, propane addition may be necessary.

BioMil AB

Why biogas upgrading?

- To increase energy density
- To remove contaminants
- To avoid corrosion

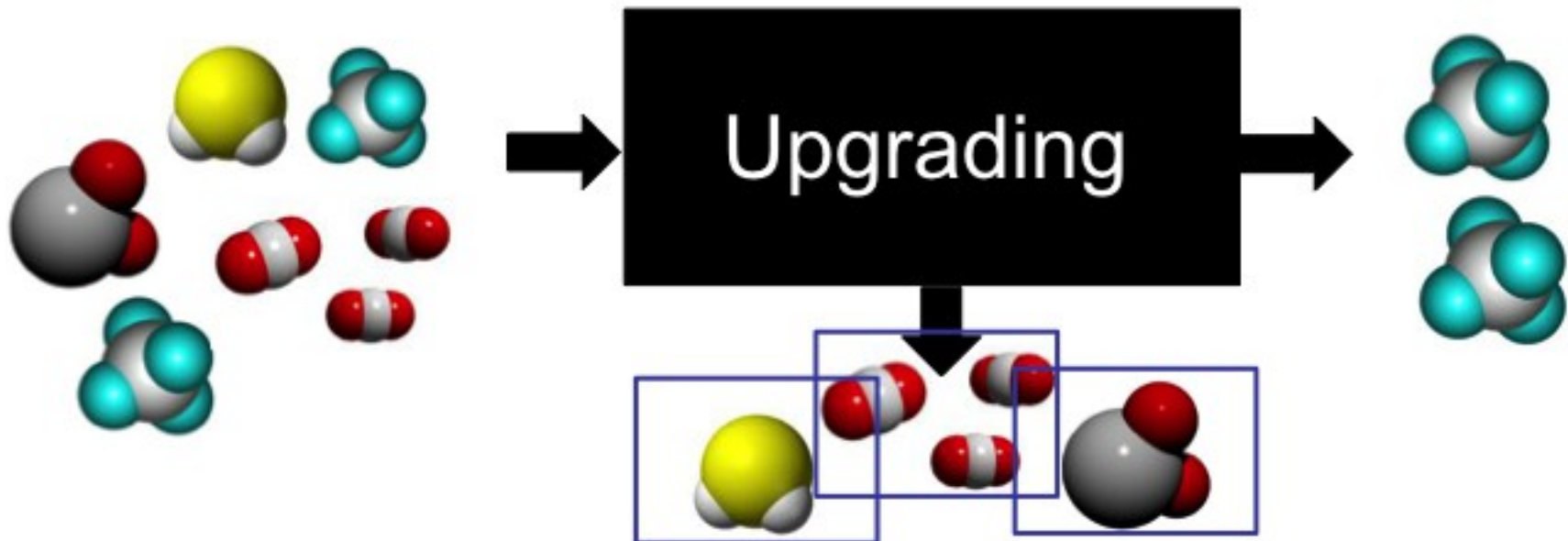

Different technology

- **Water scrubber**
- **Chemical scrubber – Amine scrubber**
- **Organic physical scrubber**
- **Membrane**
- **Pressure Swing Absorption (PSA)**
- **Cryogenic technology**

Biogas upgrading plants in operation

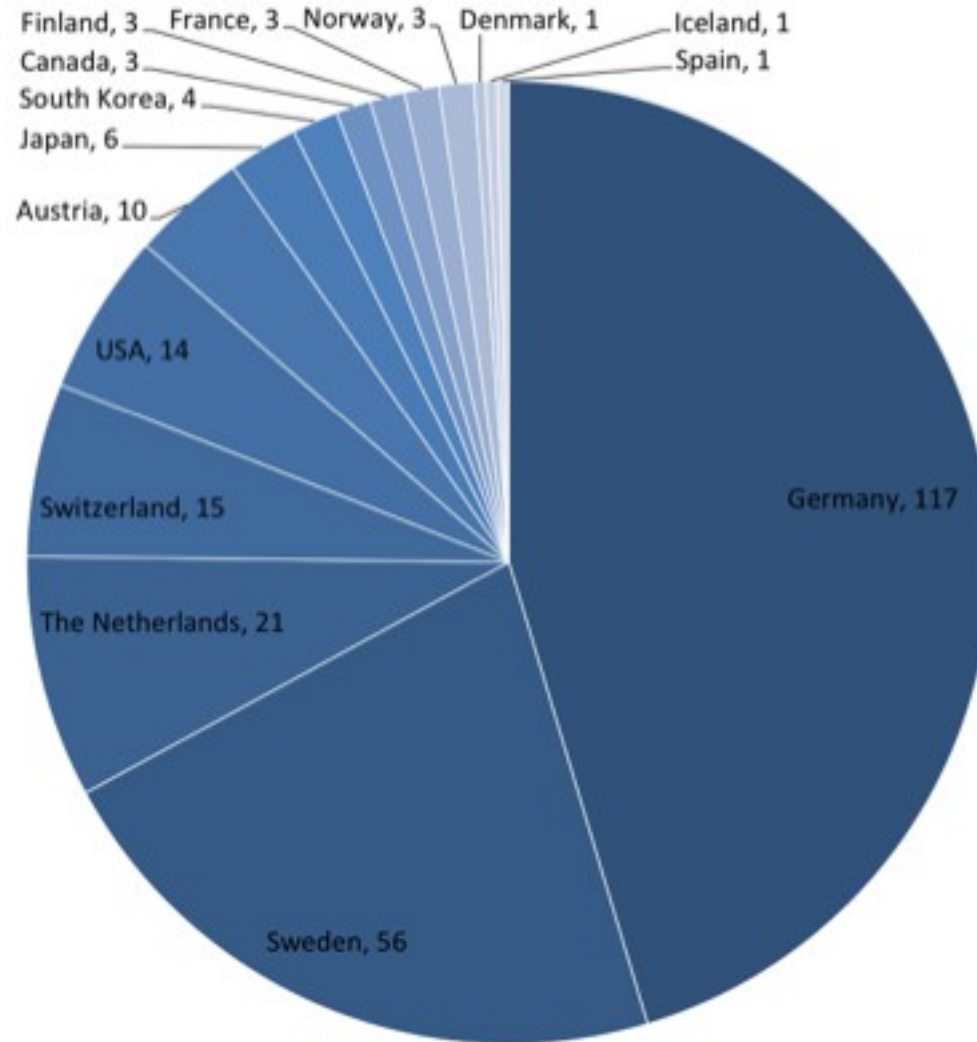

Source: IEA Bioenergy task 37

BioMil AB

Existing biogas upgrading units

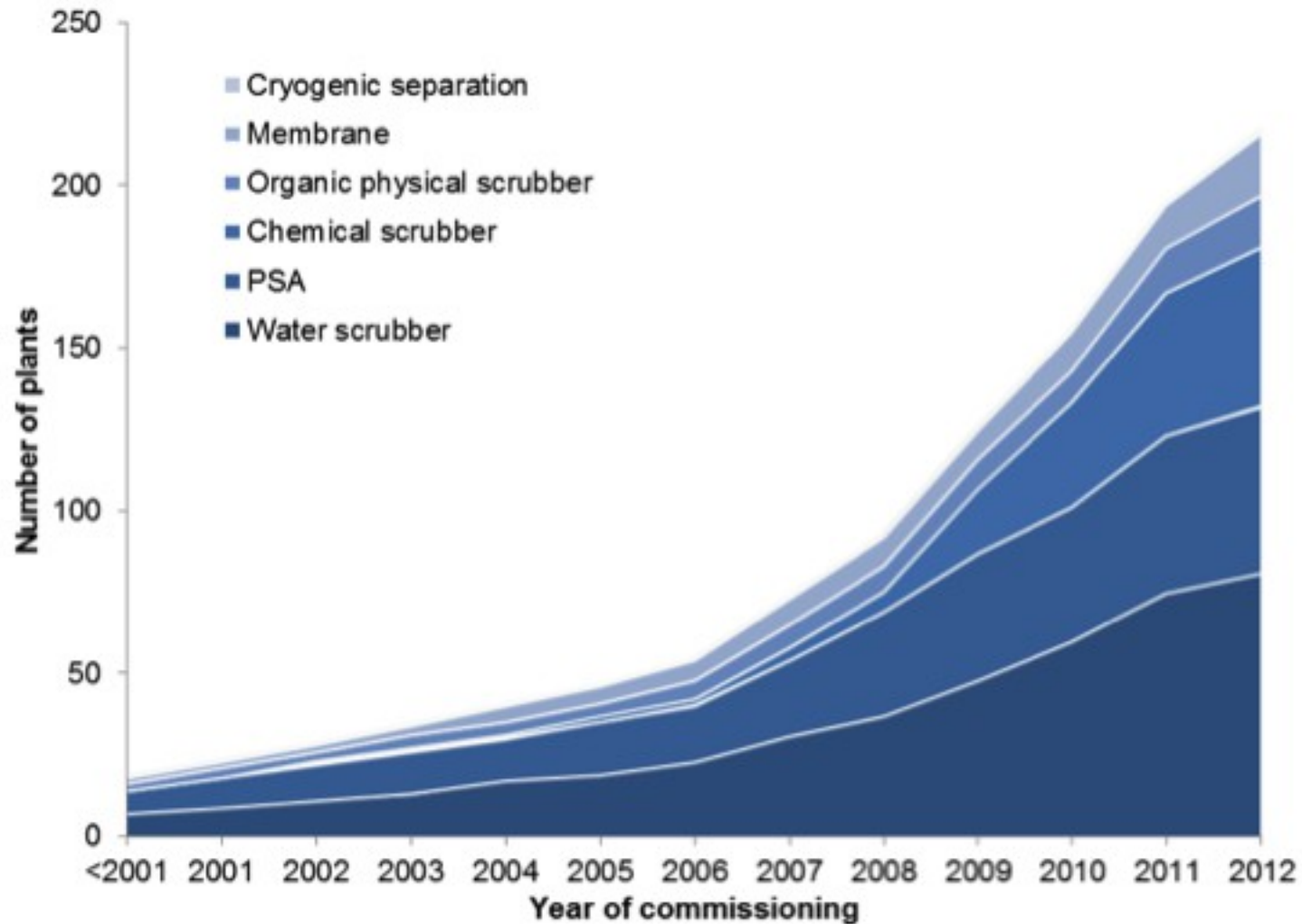

Market development

Market development

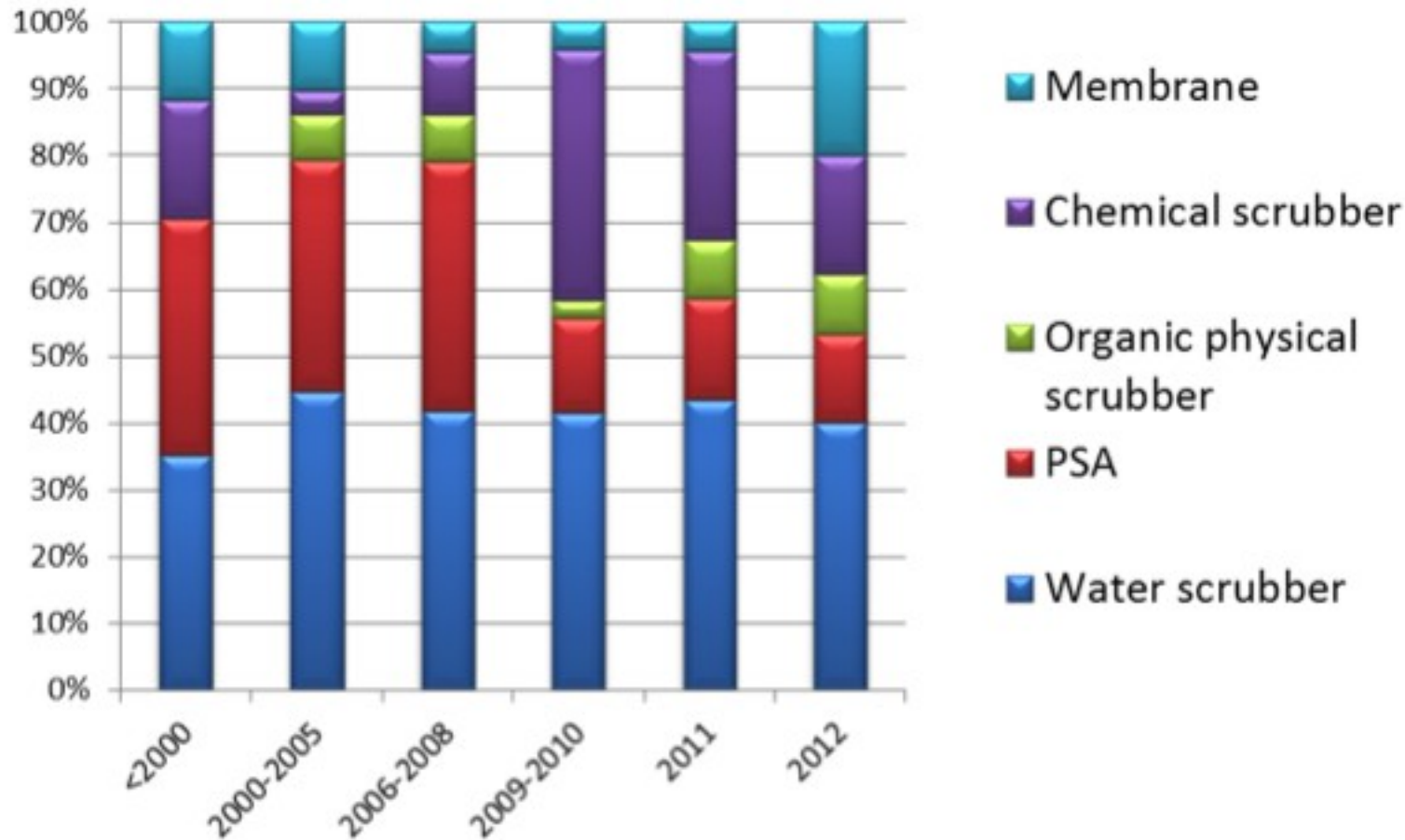

Source: IEA Bioenergy task 37

BioMil AB

Market share today

Market share today

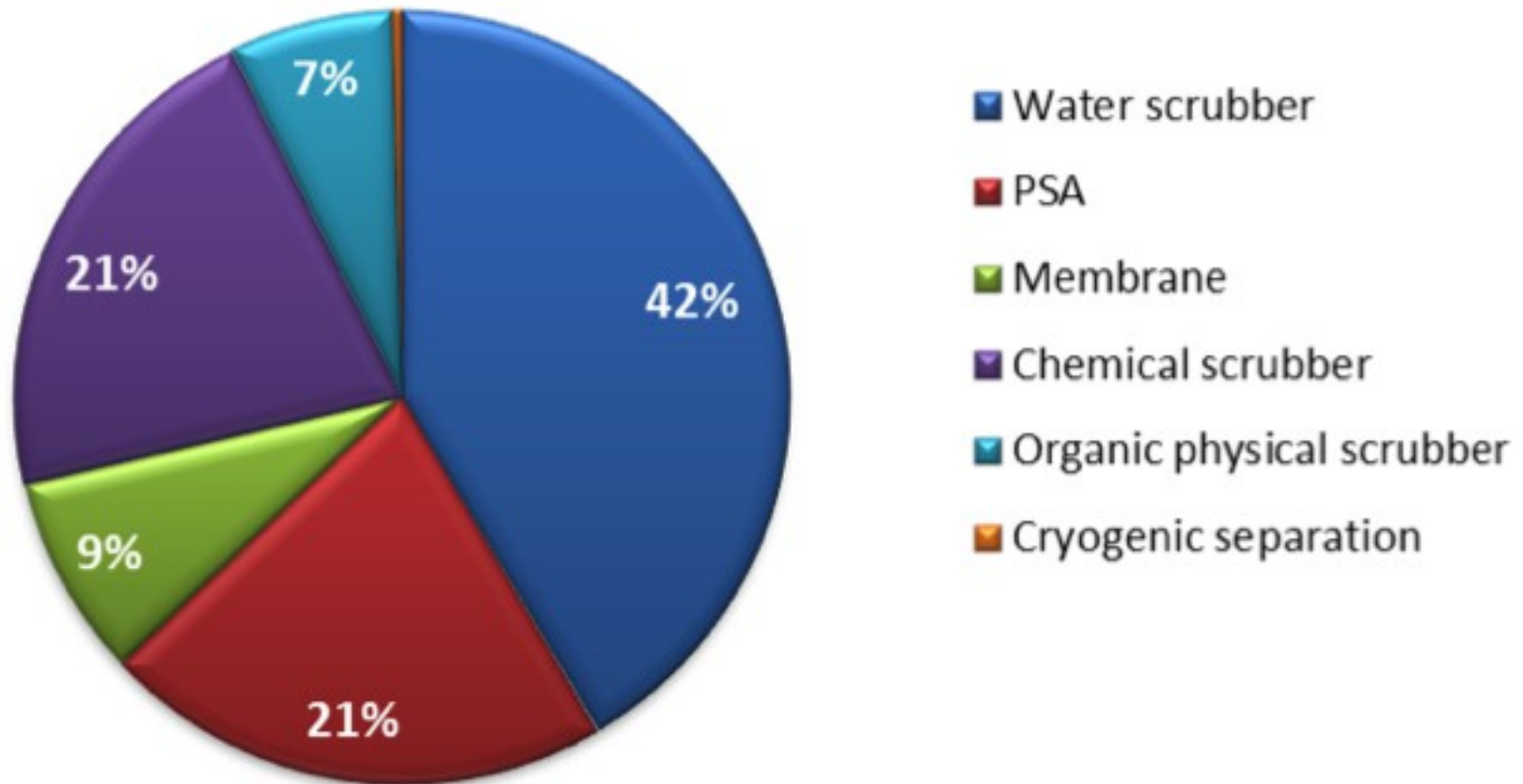

Source: IEA Bioenergy task 37

BioMil AB

Biogas as vehicle fuel in Sweden

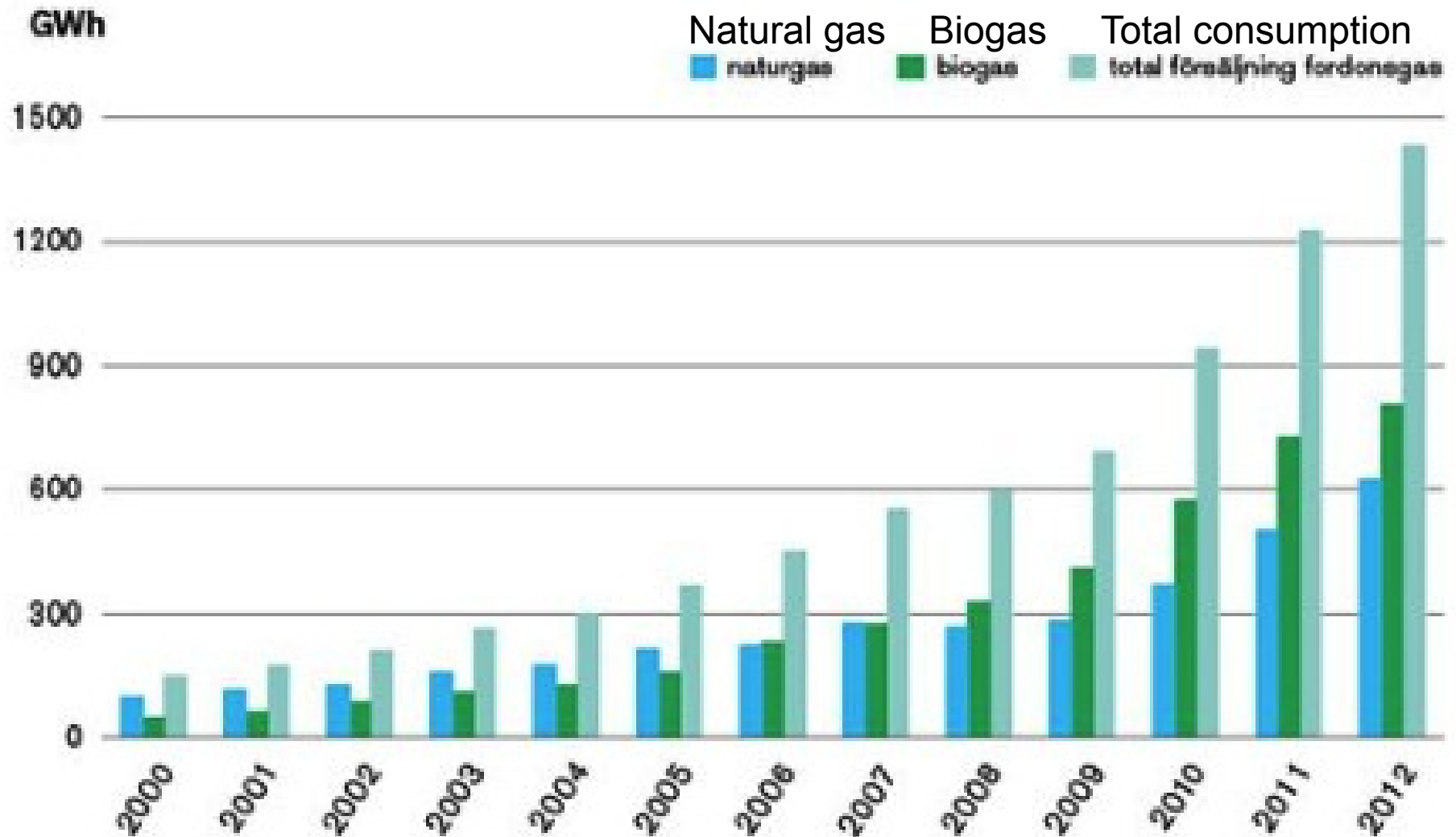

BioMil AB

Biogas as vehicle fuel in Sweden

Utilization of biogas in Sweden 2013 (GWh)

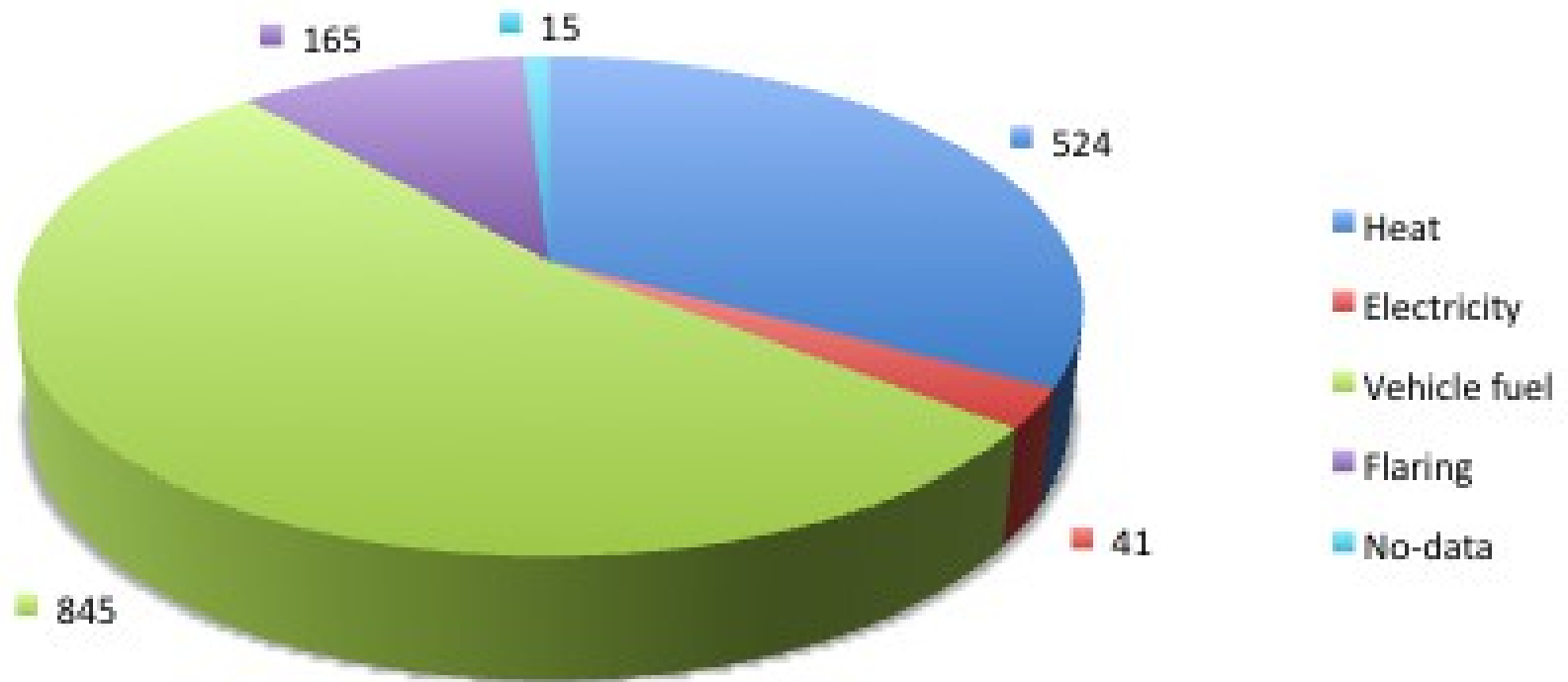

Biogas as vehicle fuel in Sweden

- ~50 000 vehicles runs on biogas
- ~200 fueling stations
- 53 upgrading plants
 - 37 Water scrubbers
 - 9 Amine scrubbers
 - 7 PSA
- 11 sites where biogas is injected to the gas grid

Different technology

- **Water scrubber**
- **Chemical scrubber – Amine scrubber**
- **Organic physical scrubber**
- **Membrane**
- **Pressure Swing Absorption (PSA)**
- **Cryogenic technology**

Water scrubber

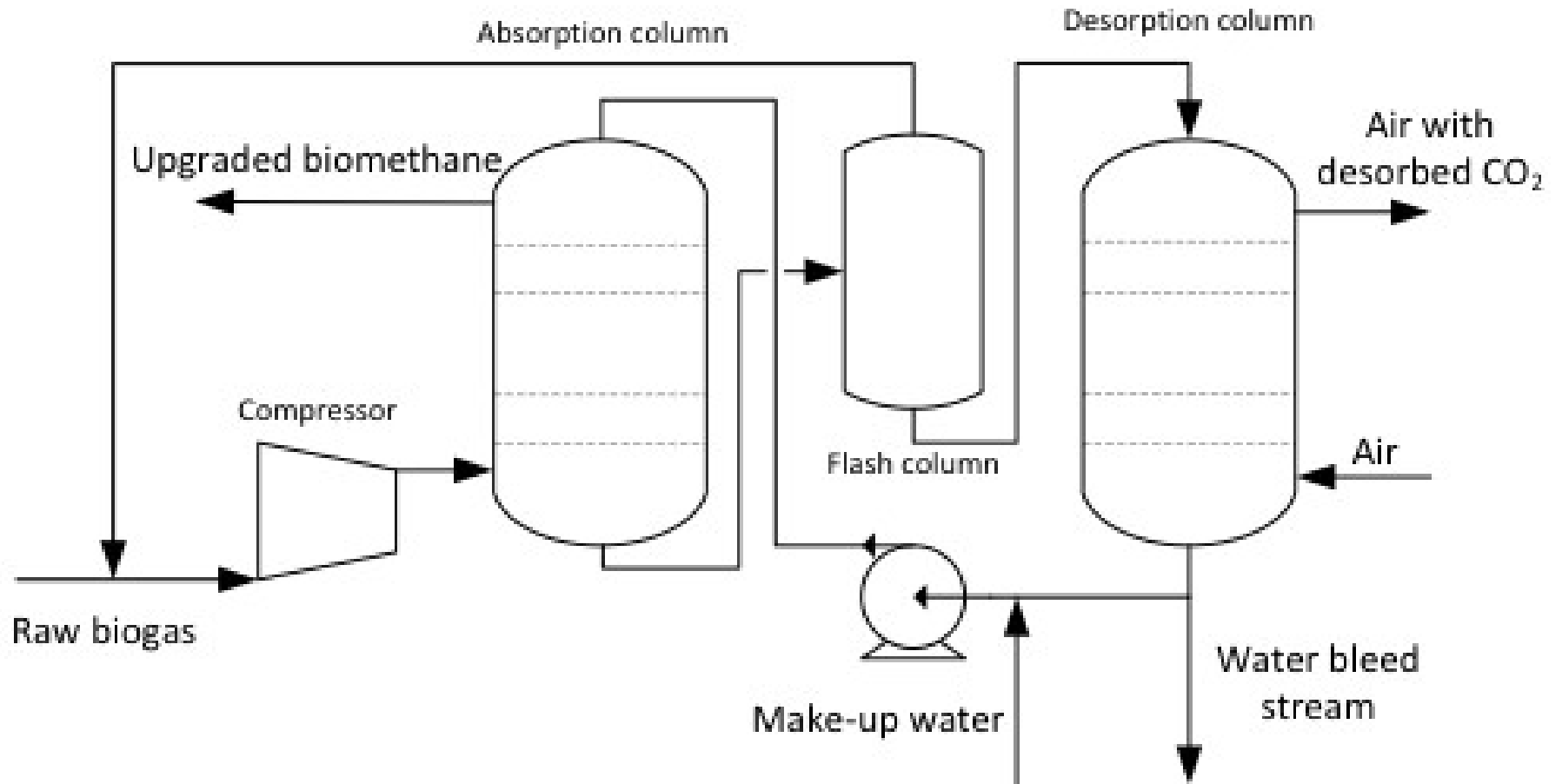

Water scrubber

Henry's law

$$C_A (M) = K_H (M/atm) * p_A (atm)$$

K_H 26 times larger for CO_2 (compared to CH_4)

Water flow

Water flow = amount of CO_2 / solubility of CO_2

$$\frac{\% CO_2 * \text{biogas flow (Nm}^3\text{/h)}}{\% CO_2 * \text{absolute pressure} * K_H}$$

*Water flow independent of
% CO_2 in the raw biogas*

Solubility in water is higher for carbon dioxide than for methane

Water scrubber

- Service – 2-3% of the investment
- Energy consumption 0,20-0,30 kWh/Nm³ raw gas (pressure, size, climate)
- H₂S – separated in the scrubber (<300-2500 ppm)
- Availability - 95-97%
- Mature technology (depending on the manufacturer)
- Methane slip 1%, RTO is needed sometimes (1,5 – 2,5 MSEK)

Amin scrubber

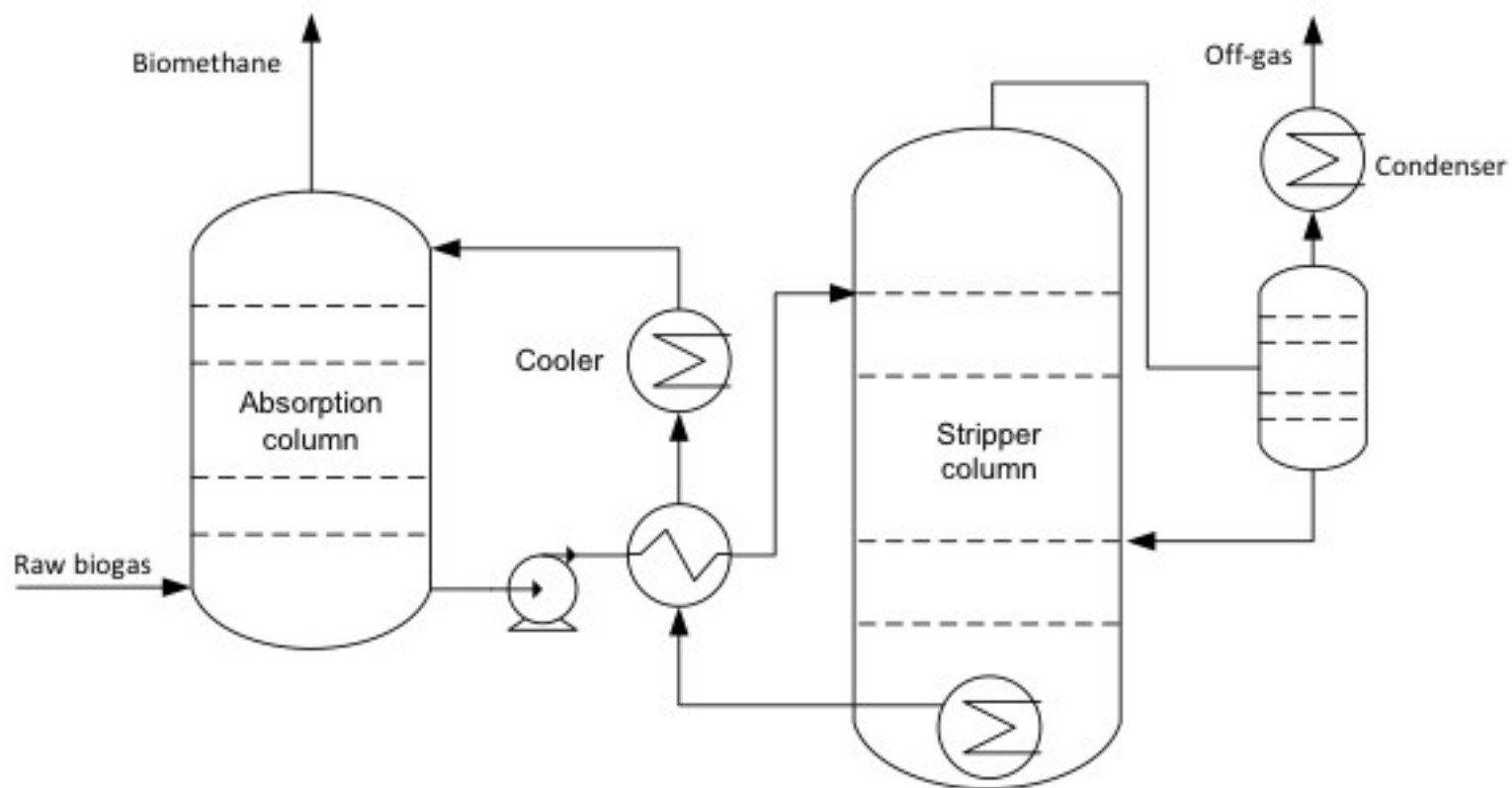

Amin scrubber

- Heat added to produce steam and to reverse the absorption reaction
- Steam lowers the partial pressure of CO₂ which drives the reaction
- Normally operated at 120-140°C (1,5-3 bar(a))
- Option to use low pressure desorption (90°C +0,05 kWh_{el}/Nm³) with DH as heat source

Amin scrubber

- Maintenance costs – 2-3% of investment
- Energy demand – $0,12-0,14 \text{ kWh}_{el}/\text{Nm}^3 + 0,55 \text{ kWh}_{heat}/\text{Nm}^3$ (low dependency on methane content)
- H_2S commonly separated prior to scrubbing, could be included with extra heat addition (10 %)
- Availability - about 96%
- Methane slip ca 0,1%
- Can deliver 98% methane
- Oxygen in raw biogas reacts irreversibly with amine

Membrane

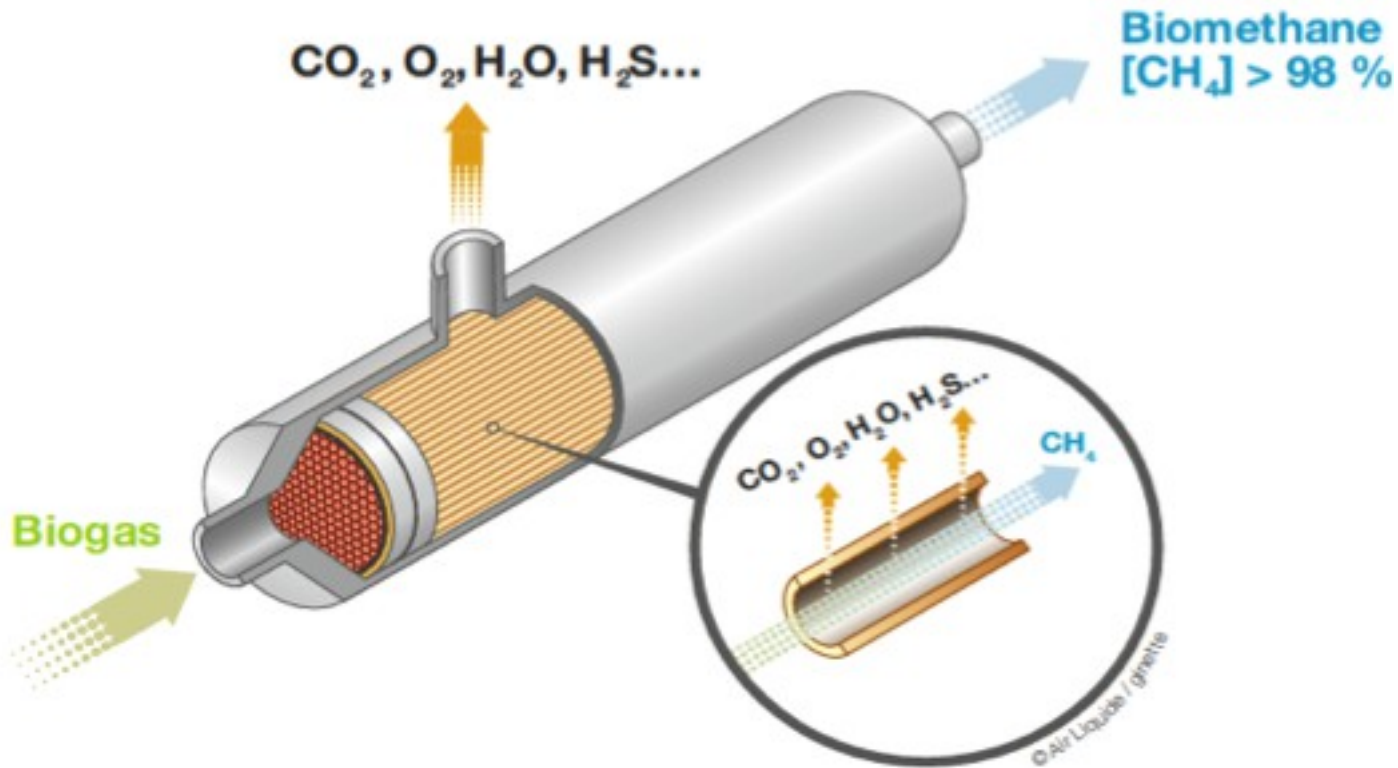

Relative permeation rate

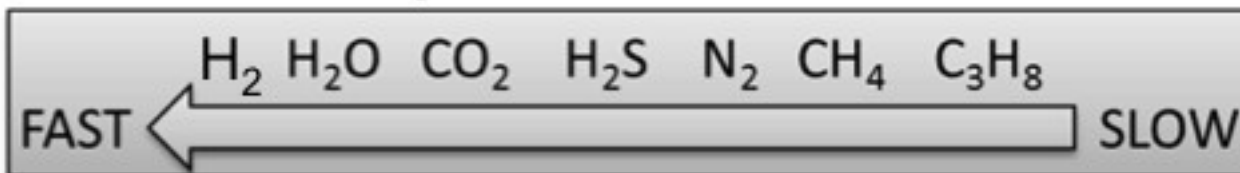

BioMil AB

Membrane on the market today

Evonik Industries



Air Liquide



BioMil AB

Membrane

- Electricity - 0,20-0,30 kWh/Nm³
(depending on the pressure and the design)
- H₂S – separated externally
- Developing technology
- Methane loss 0,5-2% (0% with Haffmans solution)
- Service 3-4% of the investment including membrane replacement
- Partly separation of oxygen

PSA

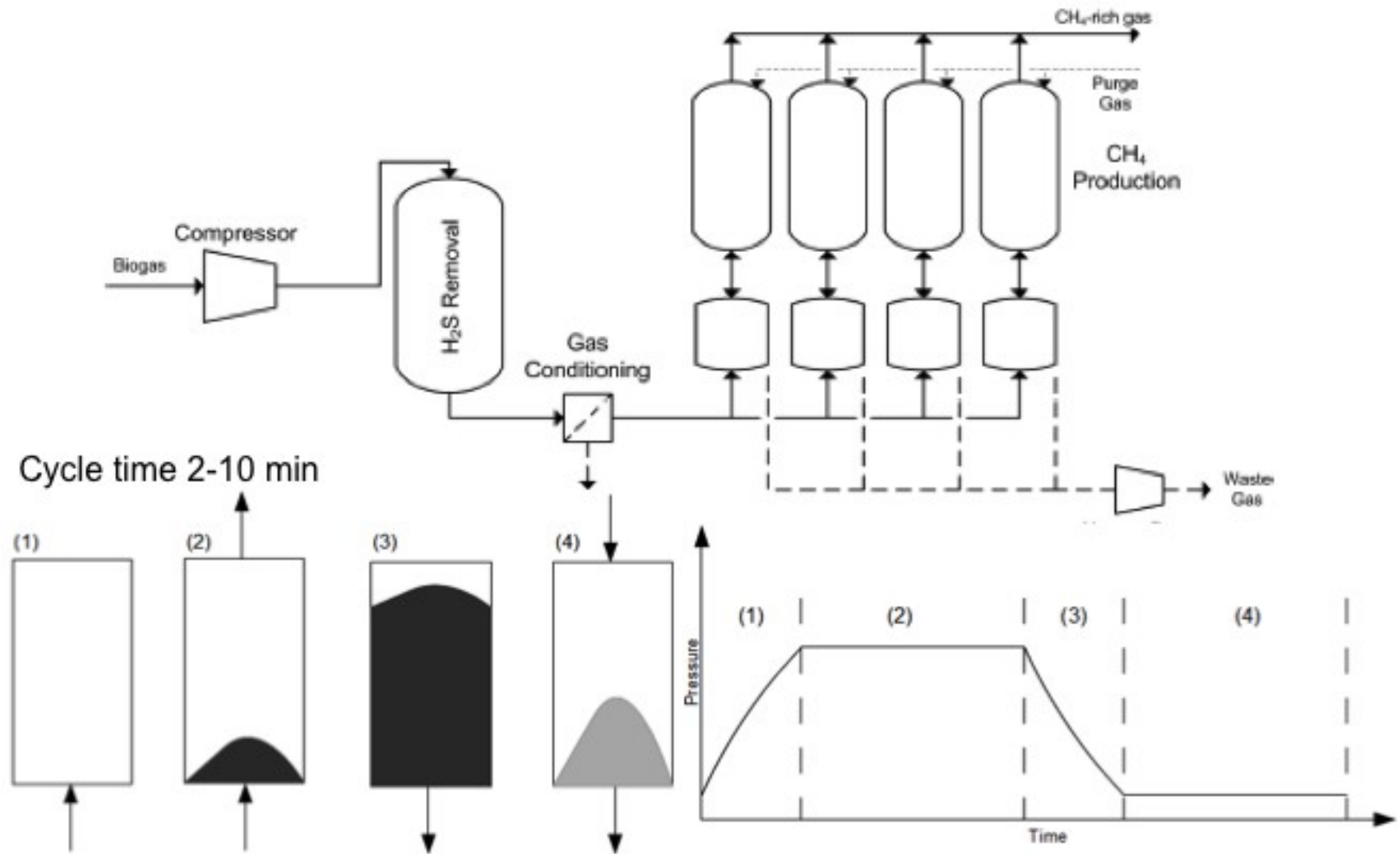

BioMil AB

PSA

- Maintenance costs – 2-3 % of investment
- Availability 96-98 %
- Energy demand – 0,2-0,3 kWh/Nm³ (0,18 kWh/Nm³ LPSA 2-3 bar(g)) (dependent on pressure and CH₄ content)
- H₂S – must be separated prior to PSA
- Mature technology
- Methane slip ca 1,5 %
- Can deliver 98 % methane according to some manufacturers

Specific investment cost

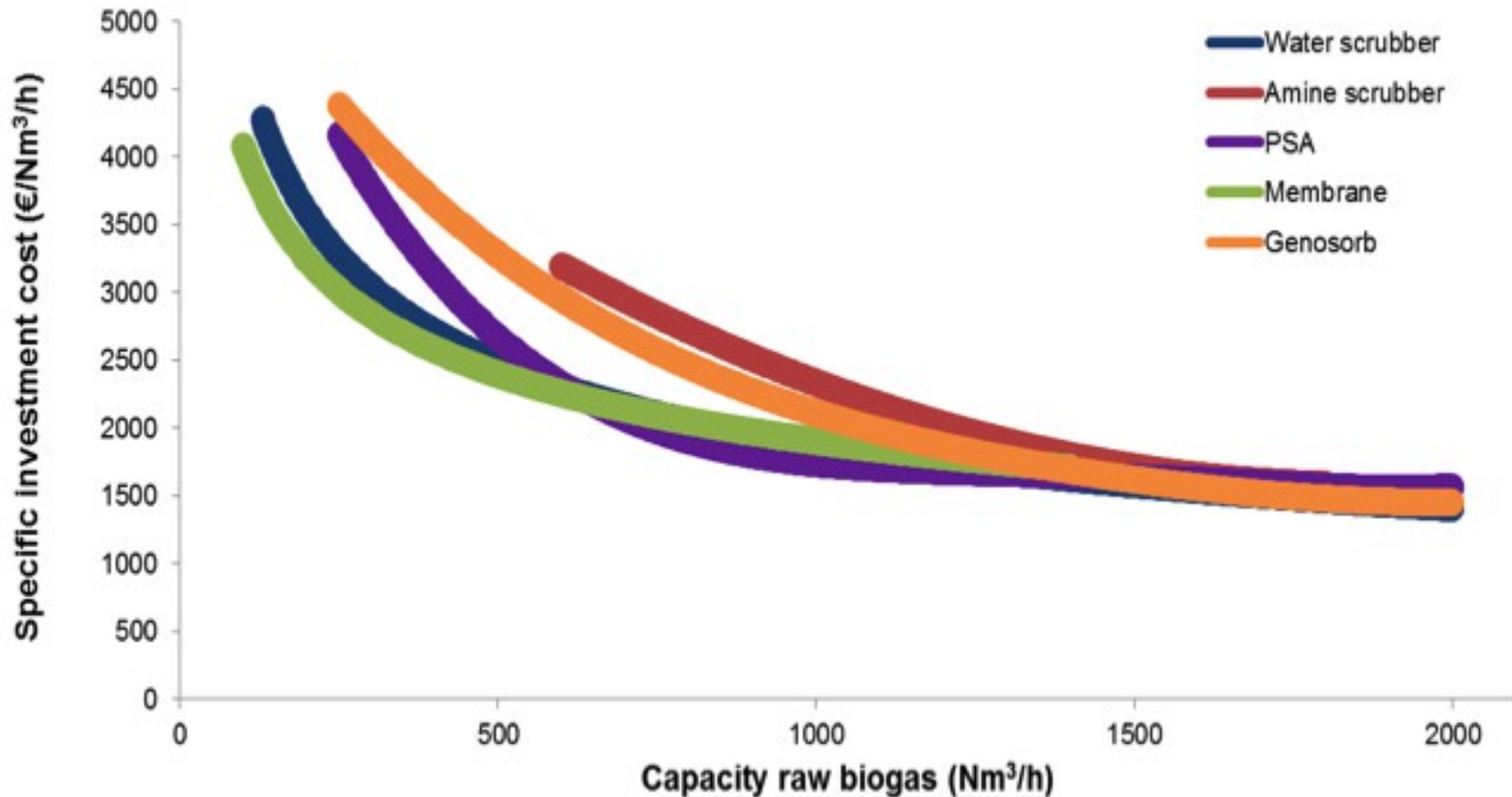

Clear economies of scale for all technologies up to about 1500 Nm³/h capacity

Specific energy demand

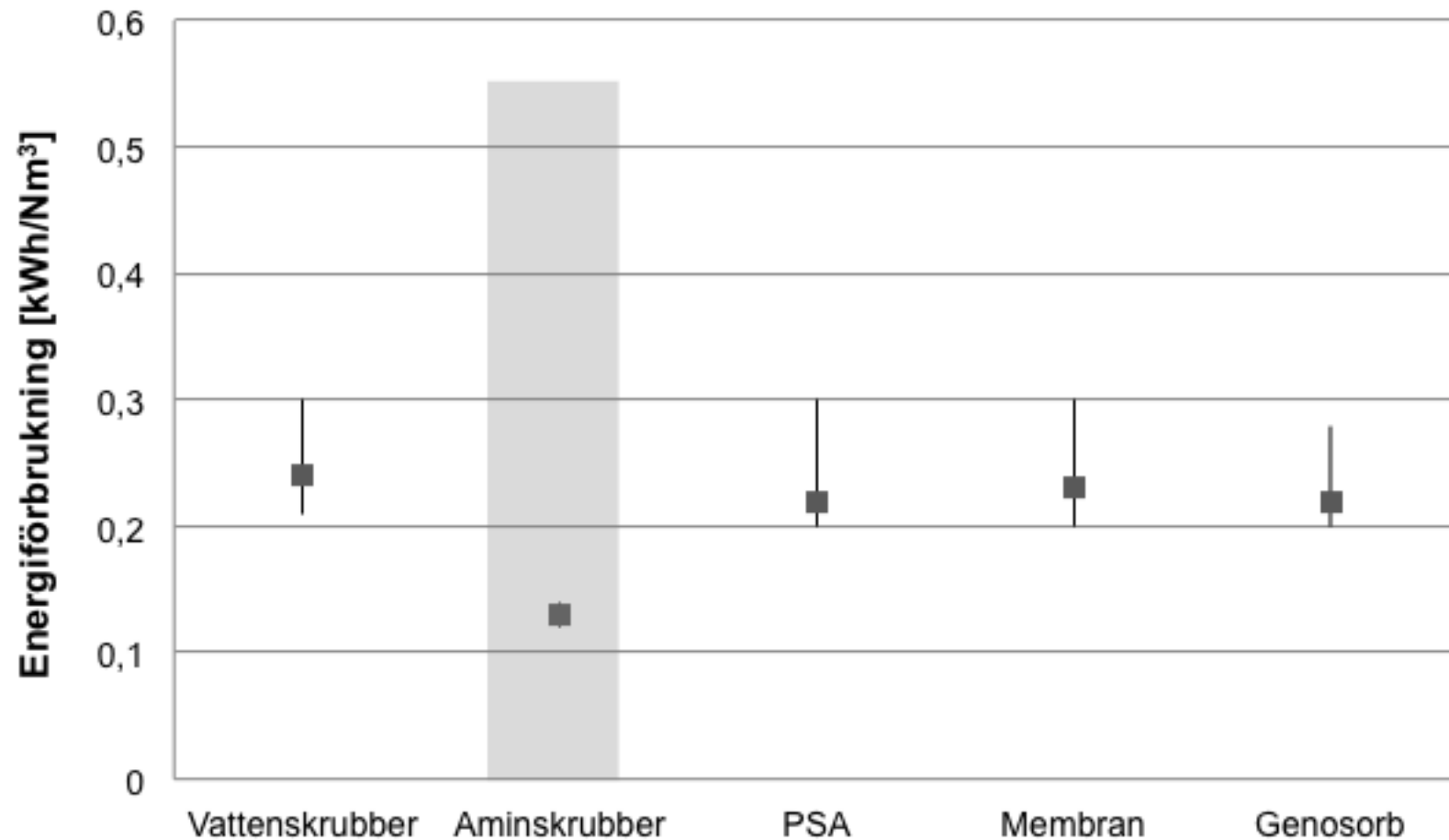

Methane slip

Technology	Methane slip
Water scrubber	1,0%
Organic scrubber	1,5%
Amine scrubber	0,1%
Membrane	0,5-2,0%
PSA	1,5-2,0%

Publications

Bauer F, Hulteberg C, Persson T & Tamm D. *SGC Rapport 270. Biogas upgrading – Review of commercial technologies*. SGC, Malmö, 2013.

Bauer F, Persson T, Hulteberg C & Tamm D. Biogas upgrading – technology overview, comparison and perspectives for the future. *Biofuels, Bioproducts and Biorefining*, 2013. DOI: 10.1002/bbb.1423

Thank you for your attention

*Martin Fransson
+46 70 320 86 06
martin.fransson@biomil.se*

BioMil AB